

# Linear Gage LG100



Read this document thoroughly before operating the product. After reading, retain it close at hand for future reference. This product is intended to be used in combination with a counter. Be sure to read the counter user's manual as well as this User's Manual for the Linear Gage.

## Safety Precautions

When using this product, be sure to observe all precautions regarding indicated specifications, functions and use. Using this product in any other manner may be detrimental to safety. In the event that the product is damaged, take all appropriate measures to avoid accidents and maintain safety.

### NOTICE

Shows risks that could result in property damage.

- Do not disassemble or modify the product. Doing so will void the warranty.
- Avoid dropping the product or subjecting it to extreme forces, such as physical jarring.
- Avoid subjecting the plunger to twisting force or lateral pressure.
- Do not use this product near the high voltage devices. Destruction of electronic components may result. Also avoid use in environments that are exposed to high levels of electrical noise.
- To avoid damage or malfunction, avoid over-tightening the stem.
- Note that the contact point might mar the surface of the workpiece depending on the workpiece material, measuring force exerted on the contact point, and the contact force applied to the workpiece. Before undertaking measurement, make sure that measurement will not affect the appearance or accuracy of the workpiece.
- Malfunction may result if this product's cable is bundled with high current power supply cables for other devices. Keep the product's cable away from power supply lines.
- The output connector plug (counter connector) is not water resistant. Do not use the product in any location that is exposed to splashing water or oil.

- Do not use the cable or rubber boot if damaged, as damage to the product may result. Either replace the part or request repair.
- The materials that are used in rubber boots and seals are not made for use with a broad range of coolants and chemicals. If these parts show noticeable deterioration, please contact the agent from whom you purchased the product or a Mitutoyo sales representative.

## Precautions for Measurement

- For accurate measurement, allow the product to warm up for at least 10 minutes after turning on the power before measuring.
- This product does not guarantee accuracy in the range within 0.2 mm of bottom of stroke (plunger fully extended).  
Perform Zero setting and Preset setting with the plunger raised at least 0.2 mm above bottom of stroke.

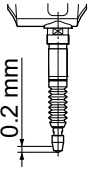

## Electromagnetic Compatibility (EMC)

This product complies with the EU EMC Directive. Note that in environments where electromagnetic interference exceeds EMC requirements defined in this directive, appropriate countermeasures are required to assure product performance. This product is an industrial product, and is not intended to be used in residential environment. If this product is used in residential environment, this product may cause electromagnetic interference with other instruments. In such a case, it is required to take appropriate measures for preventing such electromagnetic interference.

## Export Control Compliance

This product falls into the Catch-All-Controlled Goods and/or Catch-All-Controlled Technologies (including Programs) under Category 16 of Appended Table 1 of Export Trade Control Order or under Category 16 of Appended Table of Foreign Exchange Control Order, based on Foreign Exchange and Foreign Trade Act of Japan.

If you intend re-export of the product from a country other than Japan, re-sale of the product in a country other than Japan, or re-providing of the technology (including Programs), you shall observe the regulations of your country.

## Disposal of Old Electrical & Electronic Equipment (Applicable in the European Union and other European countries with separate collection systems)



This symbol on the product or on its packaging is based on WEEE Directive (Directive on Waste Electrical and Electronic Equipment), which is a regulation in EU member countries, and this symbol indicates that this product shall not be treated as household waste.

To reduce the environmental impact and minimize the volume of landfills, please cooperate in reuse and recycle.

For how to dispose of the product, please contact your dealer or the nearest Mitutoyo sales office.

## China RoHS Compliance Information

This product meets China RoHS requirements. See the table below.

产品中有害物质的名称及含量

部件名称	有害物质					
	铅	汞	镉	六价铬	多溴联苯	多溴二苯醚
	(Pb)	(Hg)	(Cd)	(Cr(VI))	(PBB)	(PBDE)
本体	×	○	○	○	○	○
配件	○	○	○	○	○	○

本表格依据 SJ/T 11364 的规定编制。

○：表示该有害物质在该部件所有均质材料中的含量均在 GB/T 26572 规定的限量要求以下。

×：表示该有害物质至少在该部件的某一均质材料中的含量超出 GB/T 26572 规定的限量要求。



环保使用期限标识是根据《电器电子产品有害物质限制使用管理办法》以及《电子电气产品有害物质限制使用标识要求 (SJ/T11364-2014)》制定的，适用于中国境内销售的电子电气产品的标识。

电器电子产品只要按照安全及使用说明内容在正常使用情况下，从生产日期算起，在此期限内产品中含有的有毒有害物质不致发生外泄或突变，不致对环境造成严重污染或对其人身、财产造成严重损害。

产品使用后，要废弃在环保使用年限内或者刚到年限的产品，请根据国家标准采取适当的方法进行处置。另外，此期限不同于质量/功能的保证期限。

## 1. Overview

This product is a precision measuring instrument (Linear Gage) that outputs linear variations as differential square waves. To measure changes in length, the Linear Gage is connected to a Mitutoyo Linear Gage counter or programmable logic controller (PLC).

### 1.1. Connectible Counters

Model number of connectible counter	Number of gages connectible	Adapter plug (optional)	Specifications
EJ-102N	2	Not required	Equipped with origin read-in function Linkable (eight counters) DIN rail mounting
EH-102Z		Required Part No. 21HZA196	Includes origin read-in function
EH-102P		Required Part No. 21HZA195	Standard 2-axis type
EH-101P	1		Standard 1-axis type

### Tips

- The optional adapter plug is required for connection to EH Series Linear Gage counters.
- For connection to counters other than the above, see "7.2 Options".

## 2. Unpacking and Verification of Package Components

Before using the product, verify that the following items are present.

Name	Quantity	Specifications
Linear Gage	1	
Contact point replacement key spanner (Part No. 538610)	One or the other	For use with 10 mm measuring range type
Key spanner for replacing contact point (Part No. 210187)		For use with 25 mm or 50 mm measuring range type
User's Manual (this document), 99MBC137B	1	
WEEE guide	1	
Warranty	1	

### 3. Name and Size of Parts

No.	Name	Specification/notes
①	Contact point	Carbide ball $\varnothing 3$
②	Plunger	Contact point mounting thread: M2.5 x 0.45
③	Rubber boot	
④	Output connector	HR10A-10P-10P (HIROSE)
⑤	Output cable	Cable length: 2 m
⑥	Stem	

- LG100-110
- LG100-0510
- LG100-0110

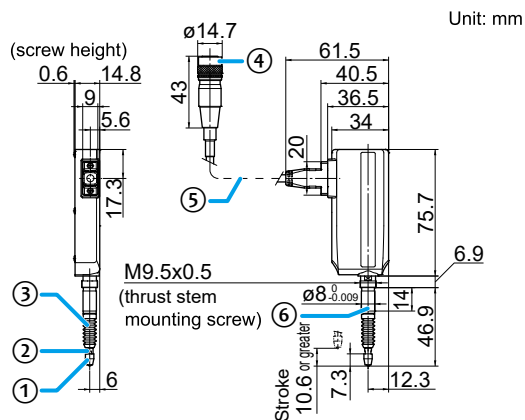

- LG100-125
- LG100-0525
- LG100-0125

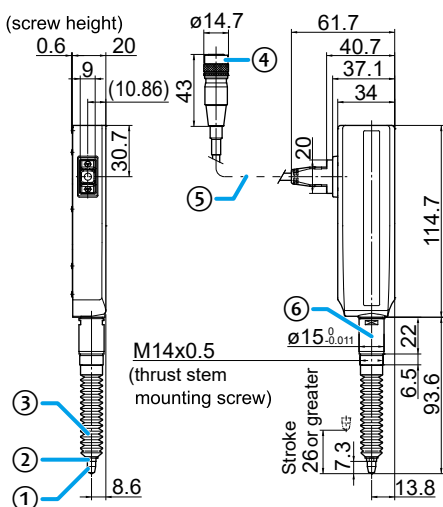

- LG100-150
- LG100-0550

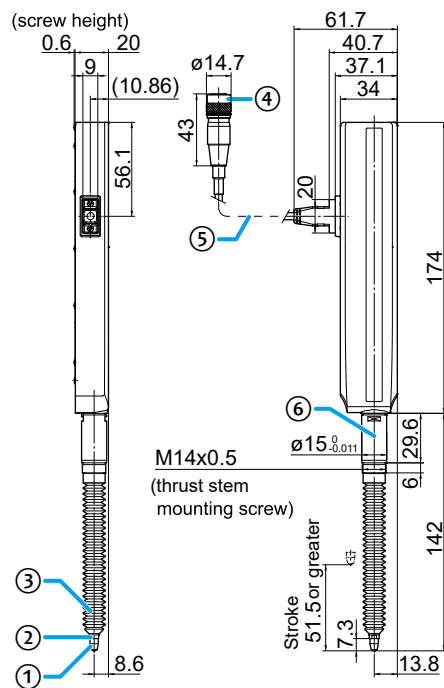

### 4. Clamping Procedure

When mounting the Linear Gauge, it must be clamped to a tool or jig with the stem.

The Linear Gauge can be clamped to the tool or jig using either a split clamp or a thrust stem (optional).

#### NOTICE

Shows risks that could result in property damage.



The following clamping methods can damage the Linear Gauge or cause improper operation. Do not use any of these methods.

- Clamping on any part other than the stem
- Applying clamping force so great that the stem is deformed
- Clamping the stem directly with a mounting screw



When fastening the stem, use a tightening torque of approximately 0.4 N•m–0.5 N•m as a guide.

## Tips

Mount the Linear Gauge parallel to the intended direction of measurement. A tilted gauge will result in measurement error.

### 4.1. Using a Split Clamp

The split clamp can fasten the stem by gripping its outer perimeter.

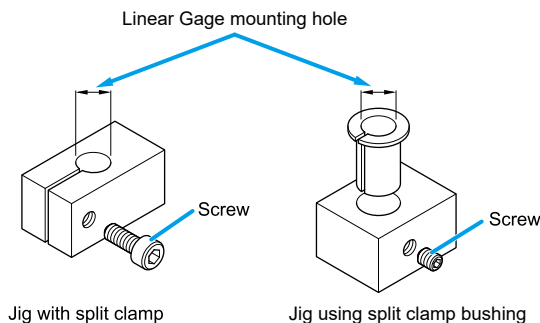

See below for mounting hole dimensions.

Measuring range	Mounting hole diameter
10 mm type	ø8 mm (+0.020/+0.005)
25 mm or 50 mm type	ø15 mm (+0.024/+0.006)

### 4.2 Using the Optional Thrust Stem

Mount the thrust stem on the Linear Gauge and fasten it to the base (tool or jig) with the fastening nut.

## NOTICE

Shows risks that could result in property damage.



Fasten the thrust stem using the special-purpose spanner (Part No. 02ADB683 or 02ADB693) while holding the stem to keep it from moving. Fastening the thrust stem without using the special-purpose spanner may result in application of excessive force between the body and stem, resulting in damage to the Linear Gauge. For the thrust stem, see  "7.2 Options".

## Tips

The M9.5 x 0.5 and M14 x 0.5 threads on the Linear Gauge are used for attaching the thrust stem. Do not use these threads for any purpose other than attaching the thrust stem.

## 1 Attach the thrust stem on the Linear Gauge.

1. Fit the optional special-purpose spanner to the spanner catches (the two grooves) at the base of Linear Gauge's stem.
2. Set the thrust stem into the plunger and then turn it with a wrench to fasten it while firmly holding the stem with the special-purpose spanner.

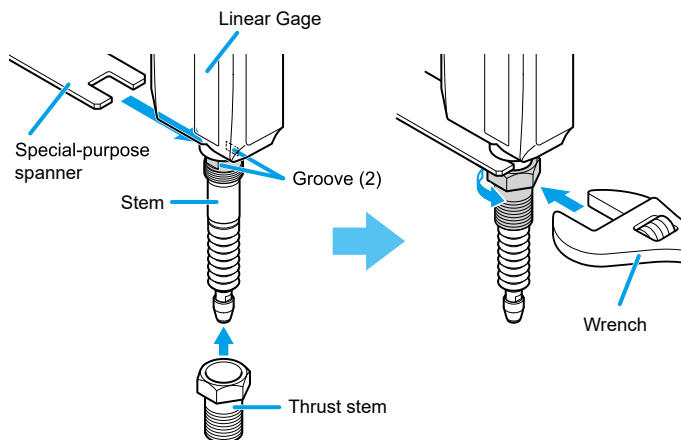

## 2 Set the Linear Gauge that attached the thrust stem into the base (tool or jig).

1. Insert the Linear Gauge that attached the thrust stem into the mounting hole on the base (tool or jig).
2. Thread the fastening nut onto the thrust stem from the plunger side, and then securely tighten the fastening nut with one wrench while holding the thrust stem with another wrench to keep it from moving.

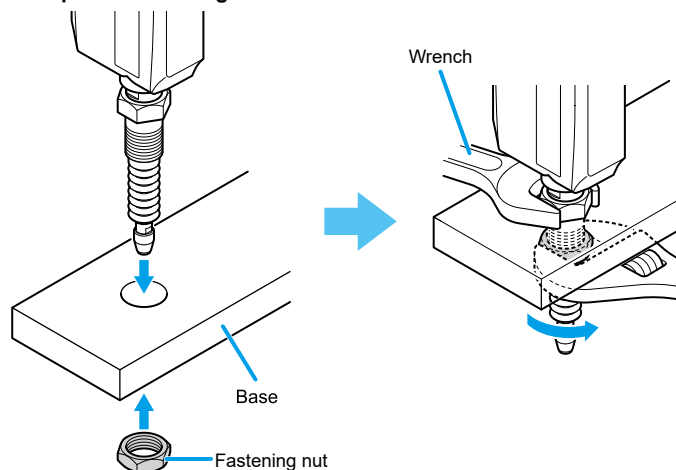

## ■ Dimensional specifications

• LG100-110 • LG100-0510 • LG100-0110

Unit: mm

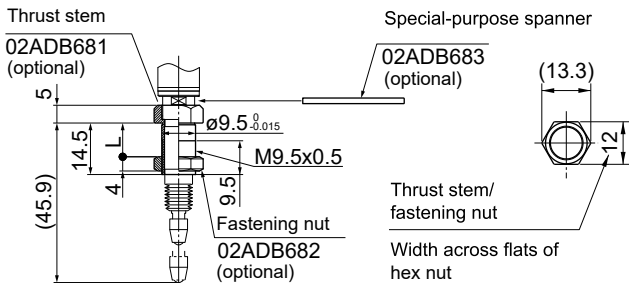

L: base thickness, use the base with a thickness of 6 mm to 10.5 mm.

• LG100-125 • LG100-0525 • LG100-0125

• LG100-150 • LG100-0550

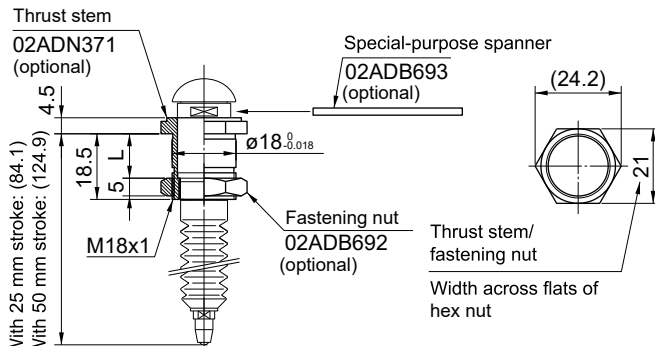

L: base thickness, use the base with a thickness of 10 mm to 13 mm.

## ■ Fastening the cable

When movement of a Linear Gage attached to the tool or jig causes repeated flexing of the cable, make sure that the cable is fixed in a manner that maintains a bending radius of at least 100 mm.

### NOTICE

Shows risks that could result in property damage.



- Fix the cable to the tool or jig so that it does not put any strain on the Linear Gage.
- Do not bend the cable more than the cable's rated bending radius. Bends that are too tight can result in broken cable wires. The bending radius is not warranted.

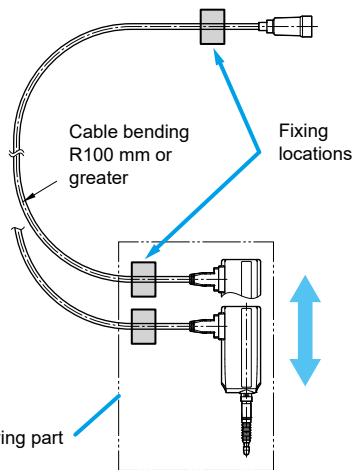

- When the cable doesn't move,  
**Cable bending radius = 50 mm or greater**

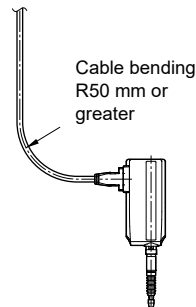

## 5. Output Signals

This section explains the signals output by the Linear Gage.

### NOTICE

Shows risks that could result in property damage.



- Malfunction may result if this product's cable is bundled with high current power supply cables for other devices. Keep the product's cable away from power supply lines.
- Electrical noise can interfere with proper operation; use a stable, noise-free power source.
- When using this product with a counter other than one made by Mitutoyo, reset the counter not sooner than 0.2 second after powering on the Linear Gage.

## 5.1. Output Connector and Signal Level

- Output connector: HR10A-10P-10P (HIROSE)
- Signal level: TD62583 line driver (AM26LS31 equivalent)
- Pin assignments:

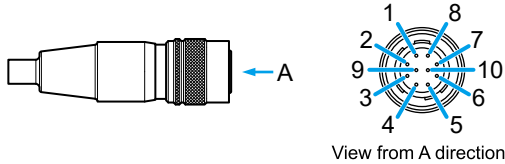

Pin No.	Signal name	Pin No.	Signal name
1	PA	7	N.C
2	$\overline{PA}$	8	$\overline{PZ}$
3	N.C	9	+5V
4	PB	10	GND
5	$\overline{PB}$	Shell	FG
6	N.C		

- Linear Gage power supply  
Power supply voltage: 5 V (4.8 V–5.2 V), voltage ripple not greater than 0.2 V<sub>pp</sub>  
Maximum power consumption: 80 mA (using recommended circuit connection)
- Compatible receptacle and jack  
Receptacle: HR10A-10R-10S (HIROSE)  
Jack: HR10A-10J-10S (HIROSE)

### ■ Recommended circuit

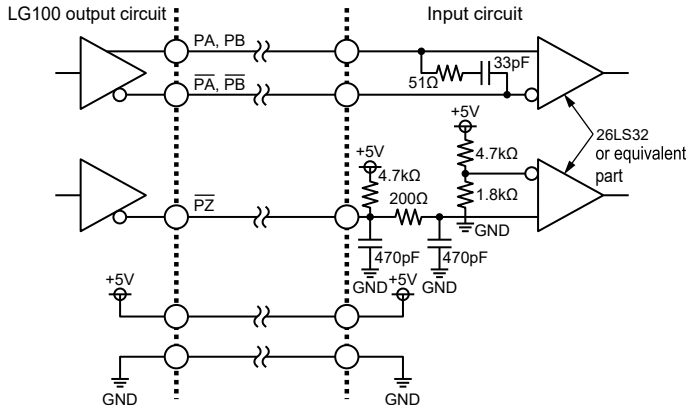

### Tips

Always use a line driver IC or differential amplifier circuit for generating the signal. Lack of differential amplification will make the signal vulnerable to noise.

## 5.2. Output Signal Chart

This product provides the following two output signal patterns. During circuit design, make sure that the receive circuit provides for error detection.

### ■ Normal output (when the plunger is pressed in)

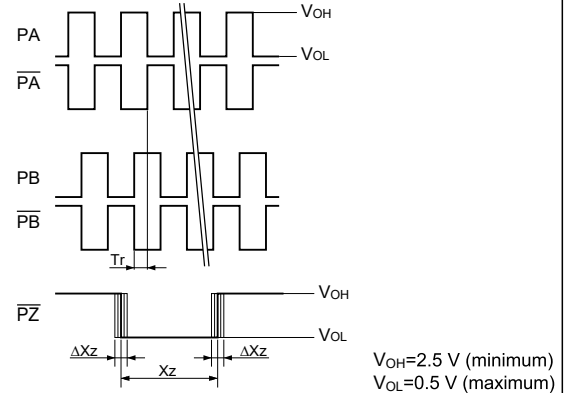

- Output condition: Speed of plunger movement  $\leq$  Linear Gage response speed<sup>\*1\*2</sup>
- Tr: Output pulse edge interval (normal output; see table below)
- Output delay time<sup>\*3</sup>: Not more than 1  $\mu$ s
- $\Delta Xz$ : Repeatability of origin position (edge reproducibility)  $\sigma \leq 0.5 \mu$ m (by traversing the origin in the same direction at a constant speed of 300 mm/s or less)
- Xz: Origin signal pulse width=approx. 40  $\mu$ m–60  $\mu$ m (reference)

### ■ Error output

When an error occurs, PA,  $\overline{PA}$ , PB, and  $\overline{PB}$  are output in phase.

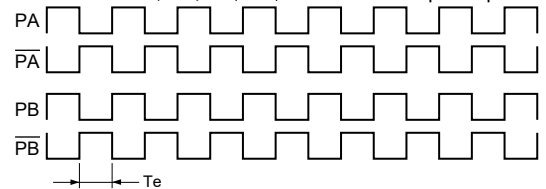

- Output conditions: The Linear Gage enters the error state and the special pattern indicated in the figure above is output under the following conditions:

- Speed of plunger movement  $>$  Linear Gage response speed<sup>\*1\*2</sup>
- Te: Output pulse edge interval (error output; see table below)

Minimum edge interval under different conditions

Resolution	Tr (normal condition)	Te (error condition)
1 $\mu$ m	500 ns	500 ns
0.5 $\mu$ m	250 ns	
0.1 $\mu$ m		

- \*1 Even if the output condition (speed) is satisfied, an error may be output due to noise or a slight speed fluctuation caused by vibration. Error output while in the stopped state may indicate an instrument fault.
- \*2 For Linear Gage response speed, see "7. Specifications".
- \*3 Indicates the time required for the counter pulse to catch up with the plunger position.

## Tips

- The error output cannot be used as counter data. Provide for error detection on the receive circuit side.
- Use of an IC capable of counting at 5 MHz or higher is recommended (for a square wave frequency of 1.25 MHz).
- Please observe the following points to ensure optimum repeatability of Linear Gage internal origin detection.
  - Always perform origin detection in the same direction. (If origin detection is performed in both directions, hysteresis in the amount of Xz will result.)
  - Make sure that the origin detection speed is 300 mm/s or less, and that the end of travel is not reached during detection.

## 6. Maintenance

### 6.1. Replacing the Contact Point

#### NOTICE

Shows risks that could result in property damage.



When replacing the contact point, always use the contact point replacement key spanner to hold the plunger stationary. Application of force through the plunger to the internal sensor can damage the sensor and render the Linear Gage inoperable.

Fit the provided contact point replacement key spanner to the spanner catches at the tip of the plunger and hold the spanner to prevent the plunger from turning (see figure at right); then cover the contact point with soft cloth and grip with pliers to remove it. Reverse the procedure to install the replacement contact point.

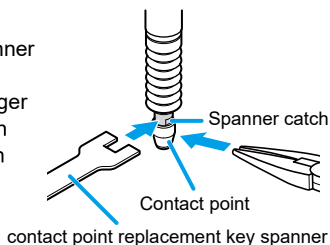

## Tips

- After attaching the contact point, make sure that it is not loose.
- Note that change of the contact point may change external dimensions and measuring force and limits movement in the direction of measurement. Also note that instrument error resulting from change of the contact point (perpendicularity, for example when replaced with a flat contact point) will have a cumulative effect on measurement accuracy.

### 6.2. Replacing the Rubber Boot

#### NOTICE

Shows risks that could result in property damage.

Damage to the rubber boot can lead to associated damage. Avoid such damage by preventively replacing the rubber boot.

## Tips

For the rubber boot, see "7.2 Options".

- 1 (For plunger with a 10 mm measuring range only) Remove the contact point from the tip of the plunger.**

See "6.1 Replacing the Contact Point".

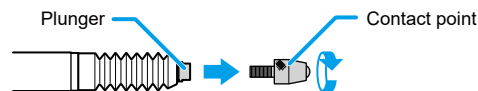

- 2 Remove the rubber boot, and then use alcohol, etc. to clean all oil and contaminants from the rubber boot attachment grooves.**

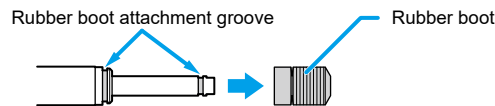

- 3 Fit the new rubber boot large-opening first onto the plunger**



- 4 Apply a small amount of silicone-based contact cement to the rubber boot attachment grooves.**

#### NOTICE

Shows risks that could result in property damage.

When doing so, be very careful to avoid getting contact cement on the plunger. Any contact cement on the plunger can damage it or render it inoperable.

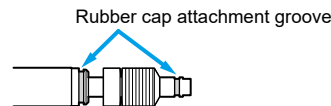

- 5 Stretch the rubber boot so that both of its ends engage the rubber boot attachment grooves. Attach the rubber cap so that it does not twist.**

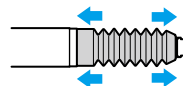

Be sure to wipe away any excess contact cement.

**6 (For plunger with a 10 mm measuring range only) Reinstall the contact point on the plunger.**

See  "6.1 Replacing the Contact Point".

**6.3. Maintenance**

Gently wipe dirt from the product with a soft, lint-free cloth (such as non-woven fabric). Do not use any organic solvents, such as detergent, thinner or benzene.

**7. Specifications**

**7.1. Specifications**

■ Common specifications

Repeatability: 2σ (20 °C)	0.3 μm
Narrow range accuracy (20 °C)	0.5 μm (arbitrary 20 μm range)
Origin signal (Z phase) repeatability: σ (20 °C)	0.5 μm (when origin is traversed in the same direction at a constant speed not exceeding 300 mm/s)
Position detection method	Photoelectric transmission-type linear encoder
Contact point	ø3 mm carbide ball (mounting screw: M2.5×0.45) (Part No.901312)
Bearing type	Linear ball bearing
Protection level	IP67G*1 equivalent (gage head only)
Output signal type	Differential square wave with 90° phase difference (RS-422A equivalent)
Power supply voltage	5 V DC (4.8 V–5.2 V), ripple voltage not greater than 0.2 Vpp
Maximum power consumption	80 mA (using recommended circuit connection)
Output connector	Plug used: HR10A-10P-10P (HIROSE) Mating receptacle: HR10A-10R-10S (HIROSE)
Output cable	2 m long (measured from main body), Sheath material: Polyurethane
Rubber boot material	HNBR (hydrogenated nitrile butadiene rubber)
Operating temperature (humidity) range	0 °C–50 °C (20%–80 % RH, without condensation)
Storage temperature (humidity) range	-10 °C–60 °C (20%–80 % RH, without condensation)
CE marking	EMC directive: EN 61326-1 Immunity test requirement: Clause 6.2 Table 2 Emission limit: Class A RoHS directive: EN IEC 63000

\*1 IP67G does not provide assurance against immersion in oil or water, or protection against all types of oils.

For details on protection level IP67, see IEC60529 and JIS C0920.  
IP6X (protection against foreign matter): Protected against ingress of foreign matter.

IPX7 (protection against water): Protected against ingress of water in quantities that would adversely affect functionality subsequent to momentary immersion for a specified amount of time at a specified pressure.

IPXXG (protection against oil): Protected against ingress of oil due to exposure from any direction.

■ Type-specific specifications

Code No.	542-190	542-191	542-192
Model No.	LG100-110	LG100-0510	LG100-0110
Measuring range	10 mm		
Resolution	1 μm	0.5 μm	0.1 μm
Accuracy (at 20 °C) L=Arbitrary measurement length (mm)	1.5 + L / 50 μm		0.8 + L / 50 μm
Measuring force	Contact point oriented downward	1.4 N or less	
	Contact point horizontally oriented	1.3 N or less	
	Contact point oriented upward	1.2 N or less	
Maximum response speed	1,500 mm/s		400 mm/s
Minimum edge interval	500 ns (2 MHz)	250 ns (4 MHz)	
Output signal pitch	4 μm	2 μm	0.4 μm
Origin signal (Z phase) position	Approx. 3 mm from tip of contact point (at bottom of stroke)		
Stem diameter	ø8		
Mass	Approx. 260 g		
Standard accessories	Key spanner for replacing contact point: No.538610		
	User's Manual (this document): 99MBC137B		



Code No.	542-193	542-194	542-195
Model No.	LG100-125	LG100-0525	LG100-0125
Measuring range	25 mm		
Resolution	1 μm	0.5 μm	0.1 μm
Accuracy (at 20 °C) L=Arbitrary measurement length (mm)	1.5 + L / 50 μm		0.8 + L / 50 μm
Measuring force	Contact point oriented downward	4.6 N or less	
	Contact point horizontally oriented	4.3 N or less	
	Contact point oriented upward	4.0 N or less	
Maximum response speed	1,500 mm/s		400 mm/s
Minimum edge interval	500 ns (2 MHz)	250 ns (4 MHz)	
Output signal pitch	4 μm	2 μm	0.4 μm
Origin signal (Z phase) position	Approx. 5 mm from tip of contact point (at bottom of stroke)		
Stem diameter	ø15		
Mass	Approx. 300 g		
Standard accessories	Key spanner for replacing contact point: No.210187		
	User's Manual (this document): 99MBC137B		

Code No.	542-196	542-197
Model No.	LG100-150	LG100-0550
Measuring range	50 mm	
Resolution	1 μm	0.5 μm
Accuracy (at 20 °C) L=Arbitrary measurement length (mm)	1.5 + L / 50 μm	
Measuring force	Contact point oriented downward	5.7 N or less
	Contact point horizontally oriented	5.3 N or less
	Contact point oriented upward	4.9 N or less
Maximum response speed	1,500 mm/s	
Minimum edge interval	500 ns (2 MHz)	250 ns (4 MHz)
Output signal pitch	4 μm	2 μm
Origin signal (Z phase) position	Approx. 5 mm from tip of contact point (at bottom of stroke)	
Stem diameter	ø15	
Mass	Approx. 400 g	
Standard accessories	Key spanner for replacing contact point: No.210187	
	User's Manual (this document): 99MBC137B	

## 7.2 Options

Name	Part No.
Rubber boot (for 10 mm measuring range type)	21HAA331
Rubber boot(for 25 mm measuring range type)	21HZA176
Rubber boot (for 50 mm measuring range type)	21HZA184
Thrust stem set (for 10 mm measuring range type*1)	02ADB680
Thrust stem (individual part)	02ADB681
Fastening nut (individual part)	02ADB682
Special-purpose spanner (for thrust stem installation with 10 mm measuring range type)	02ADB683
Thrust stem set (for 25 mm and 50 mm measuring range types*1)	02ADN370
Thrust stem (individual part)	02ADN371
Fastening nut (individual part)	02ADB692
Special-purpose spanner (for thrust stem installation with 25 mm and 50 mm measuring range types)	02ADB693
Extension cable (5 m)*2	21HZA197
Extension cable (10 m)*2	21HZA198
Extension cable (20 m)*2	21HZA199
Adapter plug (for differential square wave counter) Connectible counters*3: EH-101P (542-075), EH-102P (542-071), EG-101P (542-015), EB-11P (542-092-2), EV-16P (542-063)	21HZA195
Adapter plug (for counter with origin mark) Connectible counters*3: EH-102Z (542-073), EG-101Z (542-017), EB-11Z (542-094-2), EV-16Z (542-064)	21HZA196
Air Lifter(for 10 mm measuring range type)	02ADE230
Air Lifter(for 25 mm measuring range type)	02ADE250
Air Lifter (for 50 mm measuring range type)	02ADE270

\*1 The thrust stem set includes the thrust stem and thrust stem fastening nut. The special-purpose spanner is also required in order to tighten the thrust stem fastening nut.

\*2 Up to three extension cables can be connected, with a maximum combined length of 20 m.

\*3 For connection of older counters, please contact a Mitutoyo sales representative.

## Tips

For replacement contact points (option), please see Mitutoyo's Linear Gage catalog or contact the agent from whom you purchased the product or a Mitutoyo sales representative.